



ADVANCED PRESSURE TECHNOLOGY

Series AP 1400T

Positive Shut-off Pressure Regulator

Designed for ultra clean intermediate to high flow applications



- Stainless steel 316L AOD/VAR construction
- Absolute version available
- Cylinder or point of use specialty and bulk gases
- Flow rates to 600 slpm (21 scfm)
- Vacuum to 2,300 psig (158 bar) inlet
- Designed and manufactured exclusively for UHP semiconductor applications

687 Technology Way / Napa, CA 94558 / Telephone (707) 259-0102 / Fax (707) 259-0117

Ultraclean technology backed by service and support

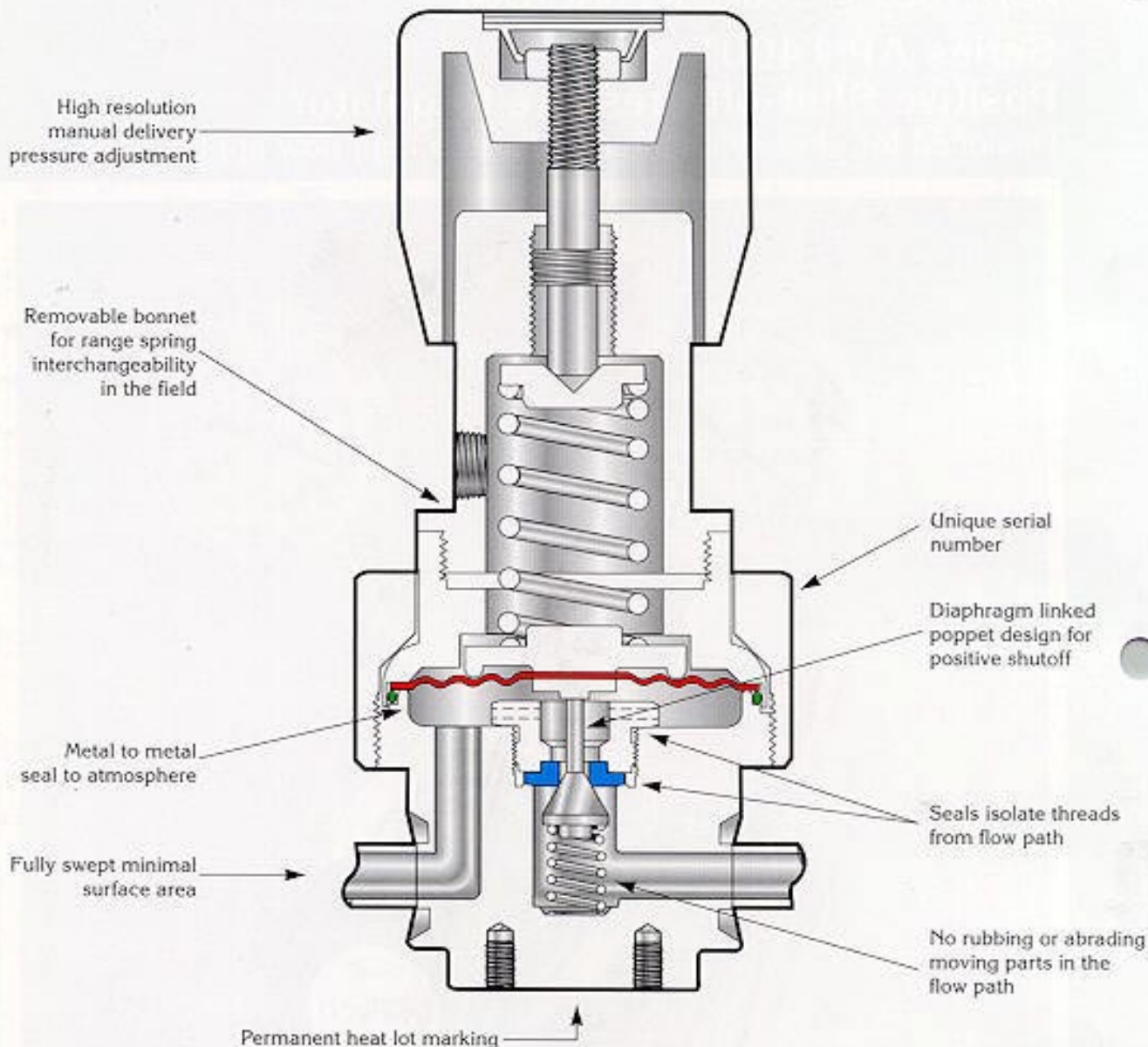

AP Tech Series AP 1400T – the ultimate in ultraclean high flow

The AP 1400T Series is a UHP regulator designed for intermediate to high flow rates of bulk and specialty gases. It provides superior performance in both source cylinder cabinet and point of use applications. The AP 1400T has a much higher flow capacity and supply pressure rating than its predecessor the AP 1400 Series. The large flow capacity also helps minimize the troublesome cooling effect inherent with higher flow rates of liquid phase cylinder gases such as HCl. Its flow characteristics are excellent, even with very low inlet and outlet pressures.

An absolute version is available which provides excellent sub-atmospheric through low positive pressure control. A non-wetted diaphragm bias spring differentiates this regulator from others within the series. (AP 1400 TA sectional view not shown.)

Ultraclean design features, as noted in the drawing above, are combined with proper surface chemistries and the most advanced manufacturing techniques available. The net result is a regulator which contributes virtually no contamination to the gas stream.

Engineering data – Series AP 1400T Pressure Regulators

Operating parameters

Source pressure (AP 1400T)	vacuum to 2,300 psig (158 bar);
Source pressure (AP 1400TA)	vacuum to 300 psig (21 bar)
Delivery pressure (AP 1402TA)	100 mm Hg absolute to 30 psig (2 bar)
Delivery pressure (AP 1402T)	1 to 30 psig (0.07 to 2 bar)
Delivery pressure (AP 1406T)	1 to 60 psig (0.07 to 4 bar)
Delivery pressure (AP 1410T)	2 to 100 psig (0.14 to 7 bar)
Proof pressure	4000 psig (276 bar)
Burst pressure	8000 psig (551 bar)

Other parameters

Inlet and outlet connectors	¼, ⅜ inch NPTF, ¼, ⅜, ½ inch face seal or tube weld
Actuation/relief port (optional)	⅜ inch NPTF
Flow coefficient (Cv)	0.45
Internal volume	0.65 in ³ (10.6 cm ³)
Operating temperature	-40° to +160°F (-40° to +71°C) *
Surface finish	10–15µin (0.25–0.38µm) standard 10µin (.25µm); 7µin (.18µm); and 5µin (.13µm) optional
Inboard leakage	2 x 10 ⁻¹⁰ sccs
Outboard leakage	2 x 10 ⁻⁹ sccs He at 1,500 psig inlet pressure
Leakage across seat	4 x 10 ⁻⁸ sccs He at 1,000 psig inlet pressure
Installation	surface or panel (optional)
Delivery pressure rise	1.6 psi per 100 inlet pressure drop

Materials

Type of Service	Series AP 1400T S Noncorrosive	Series AP 1400T SH Corrosive
Wetted Parts		
Body	stainless steel 316 L VAR	stainless steel 316 L VAR
Poppet	Hastelloy® C-22	Hastelloy C-22
Nozzle & diaphragm	stainless steel 316 L	Hastelloy C-22
Finish	electropolished and passivated	electropolished and passivated
Seat	PCTFE (Vespel® optional)*	PCTFE
Non-wetted Parts		
Bonnet, cap, plate	nickel-plated brass	nickel-plated brass
O-ring	Viton®	Viton
Stem	brass	brass

All specifications subject to change without notice.
* Higher temperature ratings available. Please consult factory.

Hastelloy® Haynes Corporation

Vespel® DuPont

Viton® DuPont

Cleaning and packaging

Cleaning is a multi-step process performed in a Class 100 clean room. Parts are ultrasonically cleaned with a wetting agent initially and then progressively with hot and cold DI water. Cleaned parts are then blown dry with ultra pure nitrogen prior to being baked completely dry in a nitrogen atmosphere.

Each regulator is then individually assembled, pressure tested, functionally tested and helium leak tested. Labels, including a unique serial number, are installed prior to products being double packaged under ultra pure nitrogen.

Uncompromising quality, performance and reliability from a company known for service and support.

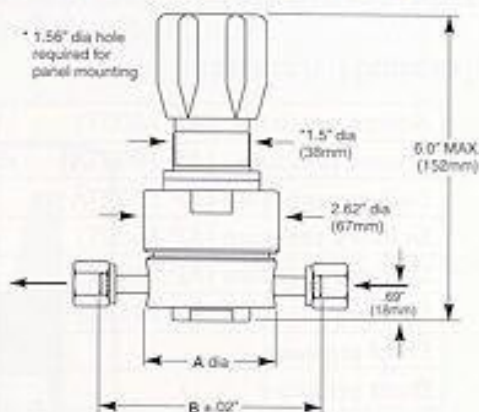
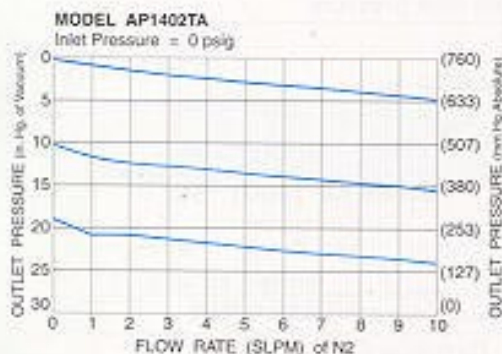
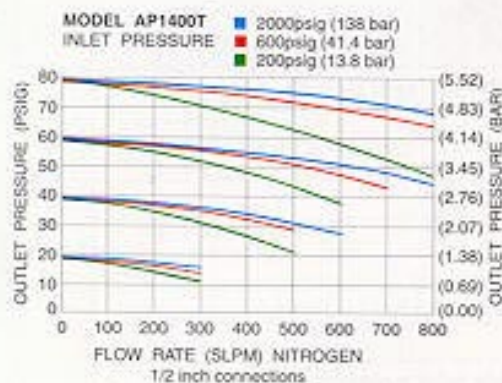
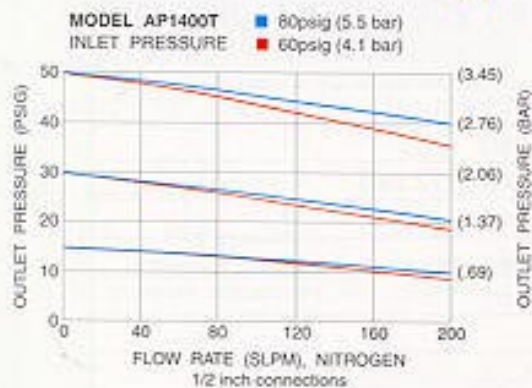

Face Seal	A	B
1/4" Male	2.00" (51mm)	4.00" (102mm)
1/4" Female	2.00" (51mm)	3.70" (94mm)
3/8"	2.50" (64mm)	5.22" (133mm)
1/2"	2.50" (64mm)	5.22" (133mm)

Porting Configuration (Bottom View)

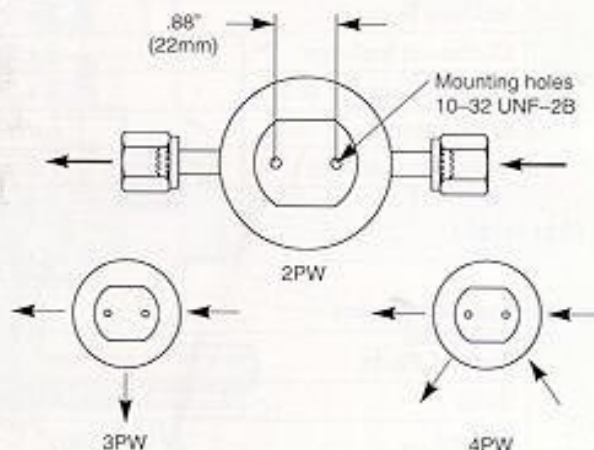

ORDERING INFORMATION

Series AP 1400T	S Material	M Surface Finish Options	A Range Options	3PW Ports	FV4 - FV4 Connections Inlet Outlet	40 - V3 Gauges** Source Delivery	P Options
AP1402T = 0-30 psi (.07 to 2 bar) AP1406T = 0-60 psi (.07 to 4 bar) AP1410T = 0-100 psi (.14 to 7 bar)	S = Stainless steel SH = Stainless steel with Hastelloy internals	M = 10µ in. Ra V = 7µ in. Ra X = 5µ in. Ra	A = 100 mm Hg absolute to 30 psig (2 bar) [AP1402T option only]	3P = 3 ports (1/4 NPTF) 2PW = 2 ports butt weld face-seal 3PW = 3 ports butt weld face-seal 4PW = 4 ports butt weld face-seal	FV4 = 1/4 inch face-seal female MV4 = 1/4 inch face-seal male	0 = No gauge V3 = 30-0-30 psi/bar L = 30-0-60 psi/bar 1 = 30-0-100 psi/bar	BV = Bonnet vent ring P = Panel installation ring* CGA = Inlet fitting 320, 330, 350 580, 660, 678 VS = Vespel seat
					4 = 1/4 inch NPT female 6 = 3/8 inch NPT female FV4 = 1/4 inch face-seal female MV4 = 1/4 inch face-seal male	2 = 0-200 psi/bar 4 = 0-400 psi/bar 10 = 0-1000 psi/bar 40 = 0-4000 psi/bar	FV6 = 3/8 inch face-seal female MV6 = 3/8 inch face-seal male FV8 = 1/2 inch face-seal female MV8 = 1/2 inch face-seal male

* Panel hole 1.56" dia.
 On panel mount option, bonnet port is not threaded.

** Welded gauge ports are always 1/4 inch face-seal male.