



ADVANCED PRESSURE TECHNOLOGY

Series AP 1600 Single Stage Pressure Regulator



- SS 316L VAR construction
- Contamination free
- Cleaned, assembled and packaged for high purity semiconductor applications.
- Vacuum to 3,500 psig (241 bar)
- 15 μ in. surface finish (10, 7 and 5 μ in. optional)

Important new features for unprecedented performance!

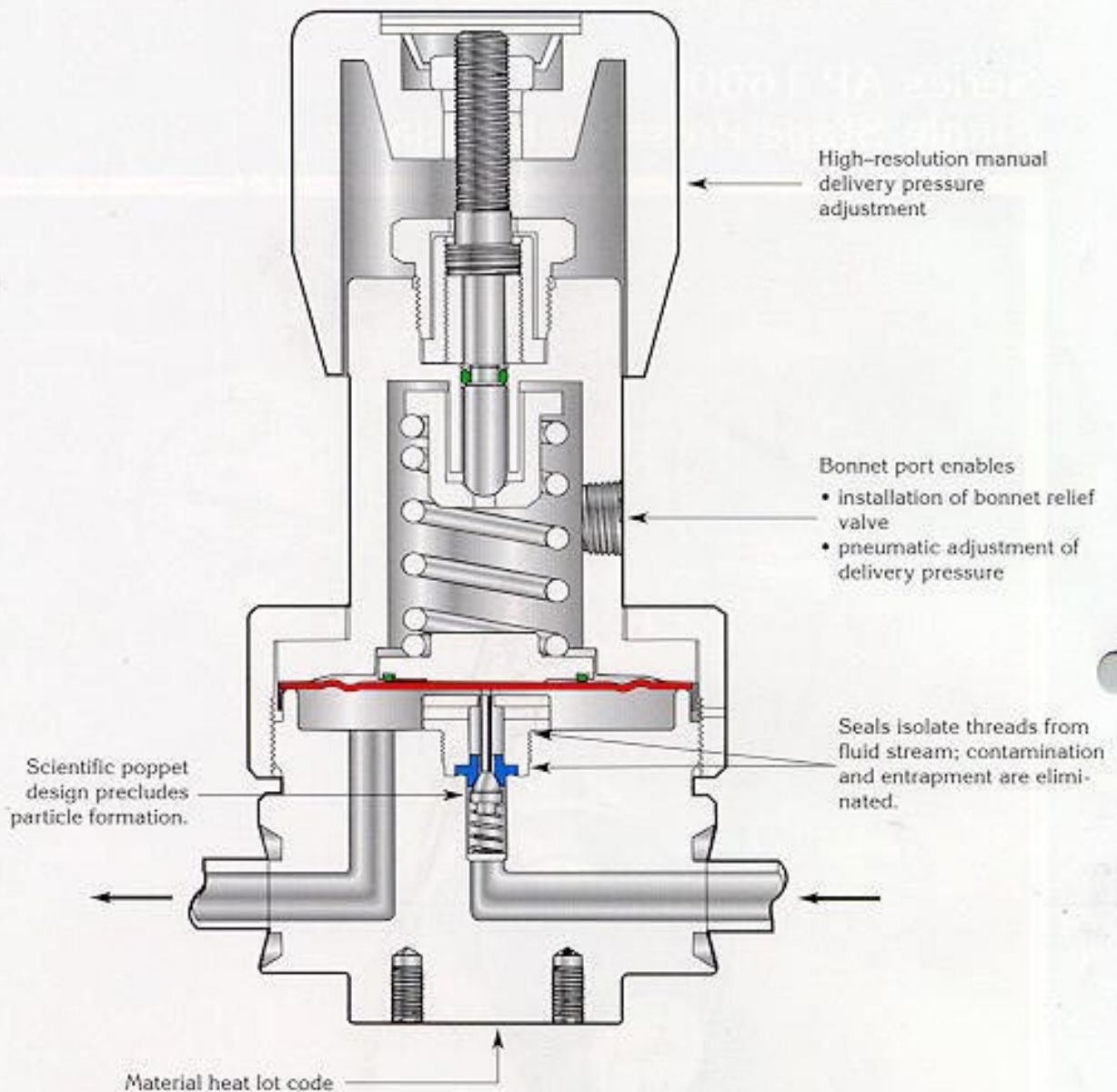

Ultraclean performance and design

The AP Tech Series AP 1600 Pressure Regulator is engineered to reliably deliver unprecedented control of high purity fluids without contributing contamination to the process stream. Though rated to full cylinder pressure, the Series AP 1600 is the regulator of choice as a line regulator for point of use applications. The large surface area of the diaphragm, coupled with the same seat as the Series AP 1000, affords excellent sensitivity and responsiveness.

The AP 1600 is an ultraclean component. There are no particle generating or abrading parts in the wetted area. The flow path is free of unswept zones and threads are isolated to minimize entrapment. The metal to metal seal of the diaphragm to the body is the only seal to atmosphere other than the port connections.

Please consult your local representative or the factory for further information or assistance.

Engineering data – Series AP 1600 Pressure Regulator

Operating parameters

Source pressure	vacuum to 3500 psig (240 bar); for AP1601, 100 psig (7 bar)
Delivery pressure (AP 1601)	1 to 10 psig (.07 to .7 bar)
Delivery pressure (AP 1601SA)	10 psig to vacuum equivalent to 100mmHg absolute
Delivery pressure (AP 1602)	1 to 30 psig (0.07 to 2 bar)
Delivery pressure (AP 1606)	2 to 60 psig (0.14 to 4 bar)
Delivery pressure (AP 1610)	2 to 100 psig (0.14 to 7 bar)
Proof pressure	4000 psig (276 bar)
Burst pressure	8000 psig (551 bar)

Other parameters

Inlet and outlet connectors	¼, ¾ or ½ inch face seal or tube weld, ¼ NPTF
Actuation/relief port	¾ inch NPT
Flow coefficient (Cv)	0.13
Internal volume	0.65 in ³ (10.6 cm ³)
Operating temperature	-40° to +160°F (-40° to +71°C)
Surface finish	10–15µin (0.25–0.4µm) standard
Inboard leakage	2 x 10 ⁻¹⁰ sccs
Outboard leakage	2 x 10 ⁻⁹ sccs He at 1500 psig inlet pressure
Leakage across seat	4 x 10 ⁻⁸ sccs He at 500 psig inlet pressure
Installation	surface or panel (optional)
Delivery pressure rise	0.25 psi per 100 psi source pressure drop

Materials

Type of Service	Series AP 1600 S Noncorrosive	Series AP 1600 SH Corrosive
Wetted Parts		
Body	stainless steel 316 L VAR	stainless steel 316 L
Poppet, diaphragm	stainless steel 316 L VAR	Hastelloy® alloy C-22
Finish	electropolished and passivated	electropolished and passivated
Seat	PCTFE (Vespel® optional)	PCTFE
Non-wetted Parts		
Bonnet, cap, plate	nickel-plated brass	nickel-plated brass
Diaphragm spring	stainless steel 302	stainless steel 302
O-ring	Viton®	Viton
Stem	brass	brass

All specifications subject to change without notice

Hastelloy® Haynes Corporation

Vespel® DuPont

Cleaning and packaging

Cleaning is a multi-step process performed in a Class 100 clean room. Parts are ultrasonically cleaned with a wetting agent initially and then progressively with hot and cold DI water. Cleaned parts are then blown dry with ultra pure nitrogen prior to being baked completely dry in a nitrogen atmosphere.

Each regulator is then individually assembled, pressure tested, functionally tested and helium leak tested. Labels, including a unique serial number, are installed prior to products being double packaged under ultra pure nitrogen.

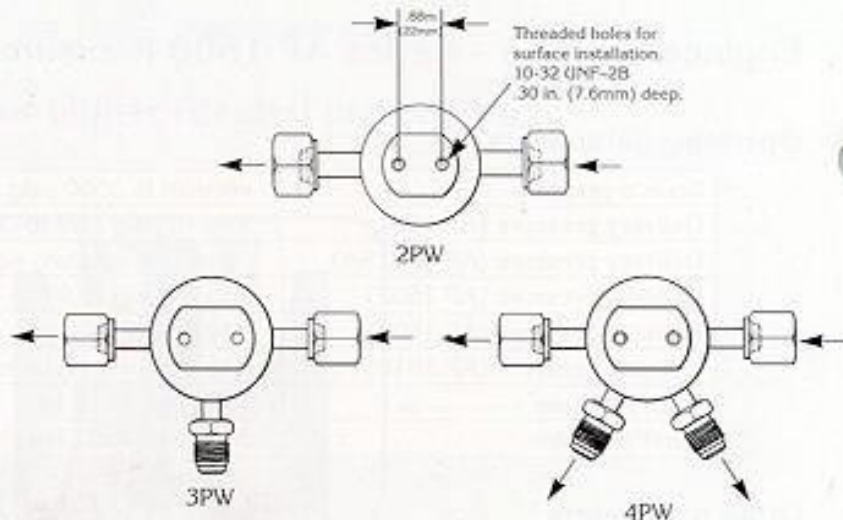
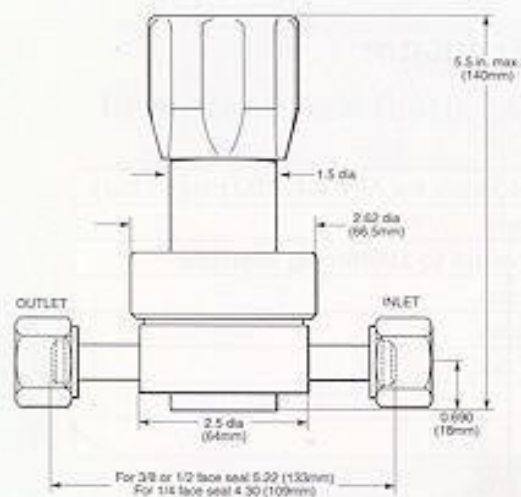

Actual test data demonstrate superior performance!

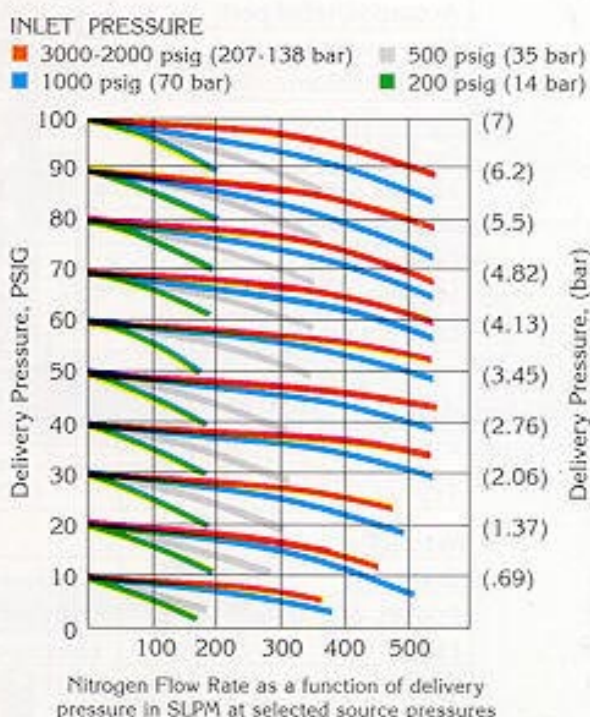
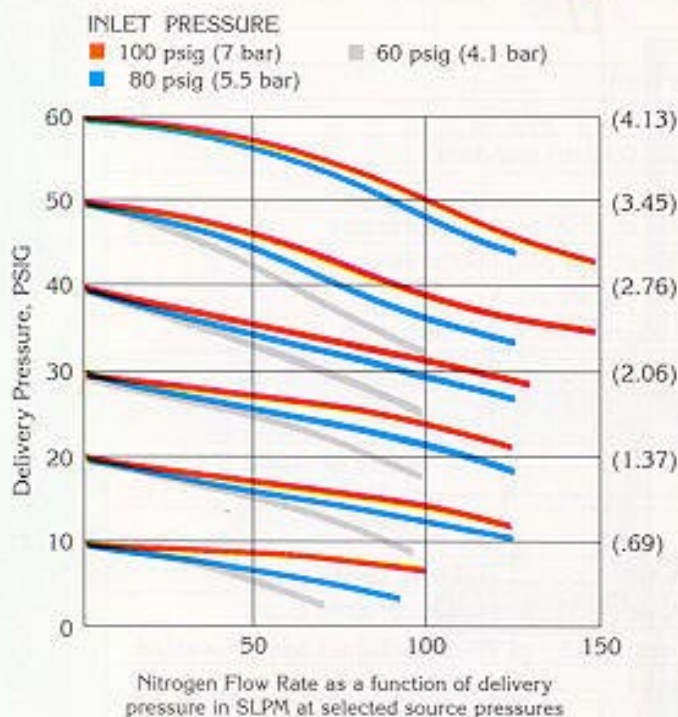

ORDERING INFORMATION

Series AP 1600	S Material	M Surface Finish Options	4PW Ports	FV4 - FV4 Connectors Inlet Outlet	40 - V3 Gauges Source Delivery*	P Options
AP1601 = 1-10 psi (.07 to .7 bar) AP1601SA = 100 mmHg to 10 psig AP1602 = 1-30 psi (.07 to 2 bar) AP1606 = 2-60 psi (.14 to 4 bar) AP1610 = 2-100 psi (.14 to 7 bar)	S = Stainless steel SH = Stainless steel with Hastelloy internals	M = 10 μ in. Ra V = 7 μ in. Ra X = 5 μ in. Ra	3P = 3 ports (1/4 NPTF) 4P = 4 ports (1/4 NPTF) 2PW = 2 ports butt weld 3PW = 3 ports butt weld 4PW = 4 ports butt weld	FV4 = 1/4 inch face-seal female MV4 = 1/4 inch face-seal male TW4 = 1/4 inch tube stub weld FV6 = 3/8 inch face-seal female MV6 = 3/8 inch face-seal male	0 = No gauge V3 = 30-0-30-psi/bar L = 30-0-60 psi/bar 1 = 30-0-100 psi/bar 10 = 0-1000 psi/bar 40 = 0-4000 psi/bar	P = Panel installation VS = Vespel seat CGA = Inlet fitting 320, 330, 350 580, 660, 678

* Gauge ports are always 1/4 inch face-seal male.