



ADVANCED PRESSURE TECHNOLOGY

Series AP 1900
Positive Shut-off Pressure Regulator
Diaphragm-Linked Poppet™



- SS 316L VAR construction
- Large diaphragm for increased sensitivity and control
- Vacuum to 3,500 psig (241 bar)
- 15 μ in. surface finish (10, 7 and 5 μ in. optional)
- Cleaned, assembled and packaged for high purity semiconductor applications.

Important new features for outstanding performance!

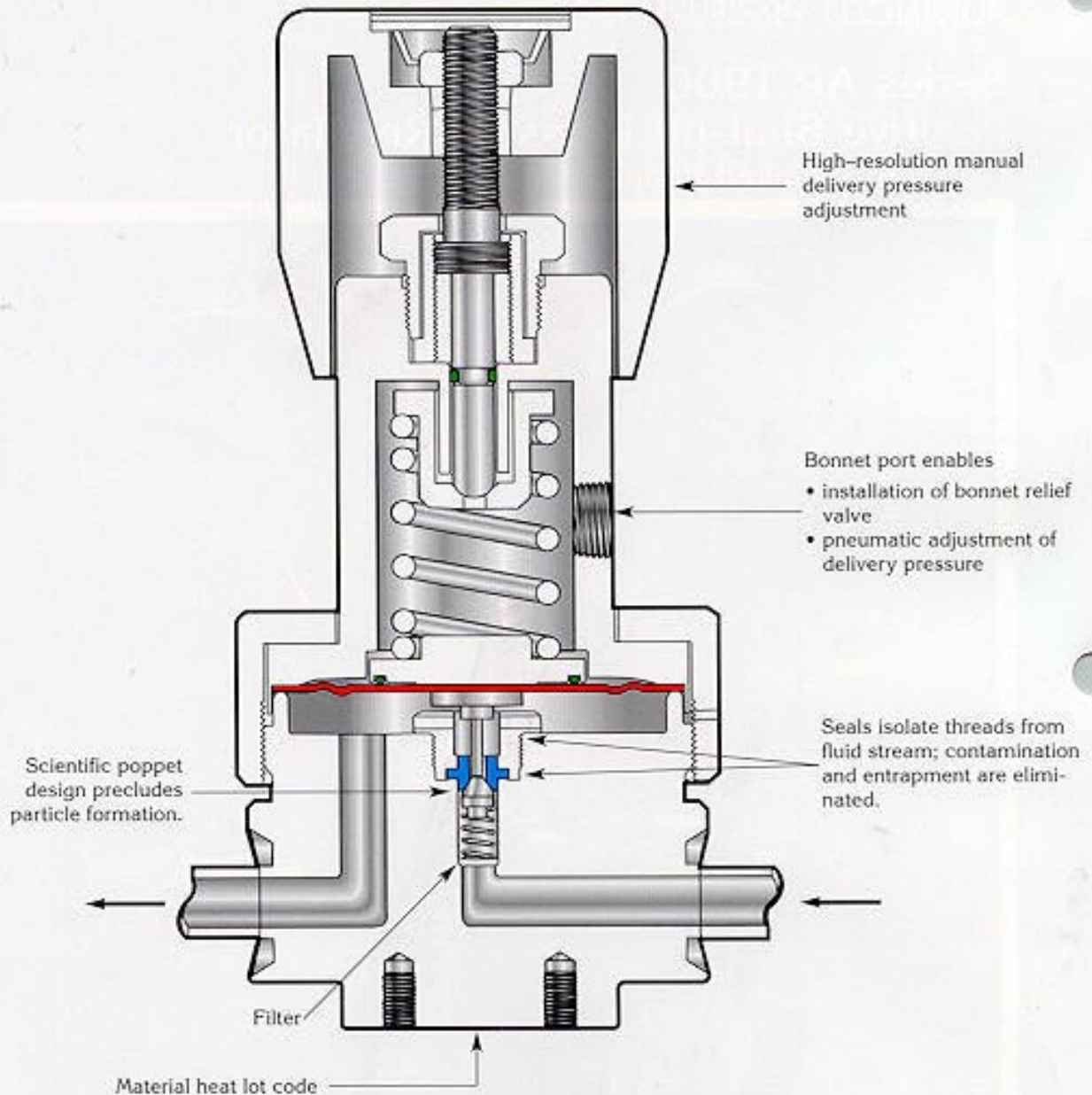

A modern pressure regulator for modern applications!

The AP Tech Series AP 1900 Pressure Regulators are engineered to deliver unprecedented control of high purity fluids without contributing contamination to the process stream. The large surface area of the diaphragm, coupled with the same seat as the 1500 Series, affords excellent sensitivity and responsiveness to this regulator which is rated from vacuum to 3500 psig supply pressure.

The metal to metal seal of the diaphragm to the body is the only seal to atmosphere other than the port connections. Only one nonmetallic seal (Kel-F) is in the wetted area. AP Tech's exclusive diaphragm-linked poppet and seat design virtually eliminate particle generation while providing positive shut-off for failsafe operation.

Engineering data – Series AP 1900 Pressure Regulator

Operating parameters

Source pressure	vacuum to 3500 psig (241 bar)
Delivery pressure (AP 1901)	1 to 10 psig (0.07 to .7 bar)
Delivery pressure (AP 1902)	1 to 30 psig (0.07 to 2 bar)
Delivery pressure (AP 1906)	2 to 60 psig (0.14 to 4 bar)
Delivery pressure (AP 1910)	2 to 100 psig (0.14 to 7 bar)
Proof pressure	4000 psig (276 bar)
Burst pressure	8000 psig (552 bar)

Other parameters

Inlet and outlet connectors	¼, ⅜ or ½ inch face seal or tube weld, ¼ NPTF
Actuation/relief port	¼ inch NPT
Flow coefficient (Cv)	0.13
Internal volume	0.65 in ³ (10.6 cm ³)
Operating temperature	-40° to +160°F (-40° to +71°C)
Surface finish	10–15µin (0.25–0.4µm) 15µin (0.25µm); 7µin (0.18µm); and 5µin (0.13µm) optional
Inboard leakage	2 x 10 ⁻¹⁰ sccs
Outboard leakage	2 x 10 ⁻⁹ sccs He at 1500 psig inlet pressure
Leakage across seat	4 x 10 ⁻⁸ sccs He at 1000 psig inlet pressure
Installation	surface or panel (optional)
Delivery pressure rise	0.25 psi per 100 psig source pressure drop

Materials

Type of Service	Series AP 1900 S Noncorrosive	Series AP 1900 SH Corrosive
Wetted Parts		
Body	stainless steel 316 L VAR	stainless steel 316 L VAR
Poppet, diaphragm	stainless steel 316 L VAR	Hastelloy® alloy C-22
Finish	electropolished and passivated	electropolished and passivated
Seat	PCTFE (Vespel® optional)	PCTFE
Non-wetted Parts		
Bonnet, cap, plate	nickel-plated brass	nickel-plated brass
Diaphragm spring	stainless steel 302	stainless steel 302
O-ring	Viton®	Viton
Stem	brass	brass

All specifications subject to change without notice

Vespel® DuPont
Viton® DuPont

Hastelloy® Haynes Corporation

Cleaning and packaging

Cleaning is a multi-step process performed in a Class 100 clean room. Parts are ultrasonically cleaned with a wetting agent initially and then progressively with hot and cold DI water. Cleaned parts are then blown dry with ultra pure nitrogen prior to being baked completely dry in a nitrogen atmosphere.

Each regulator is then individually assembled, pressure tested, functionally tested and helium leak tested. Labels, including a unique serial number, are installed prior to products being double packaged under ultra pure nitrogen.

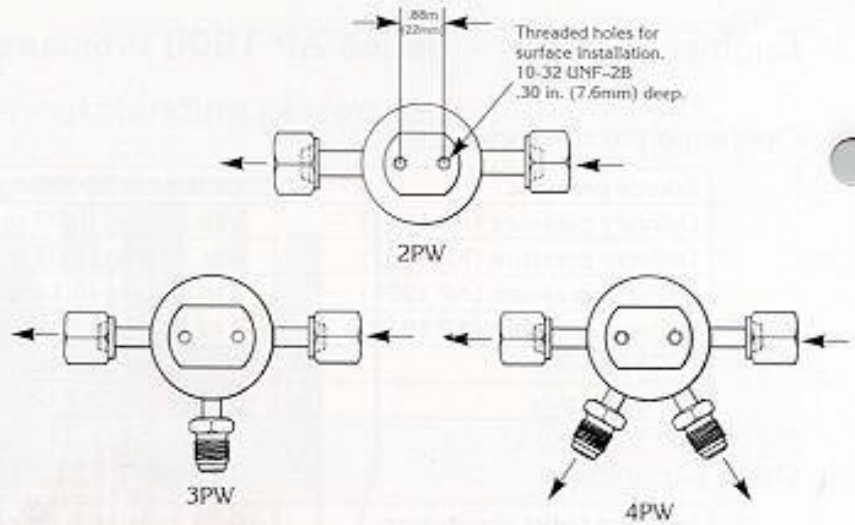
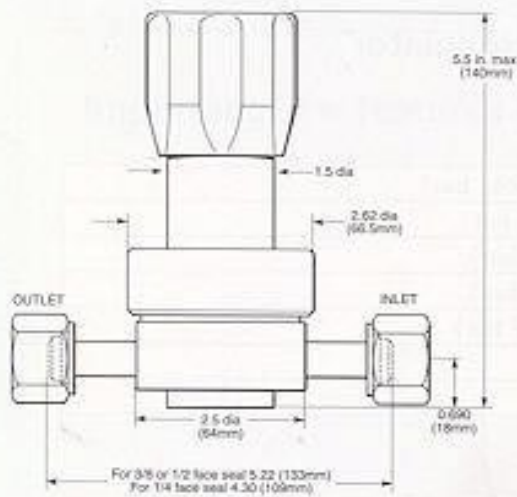

Actual test data demonstrate superior performance!

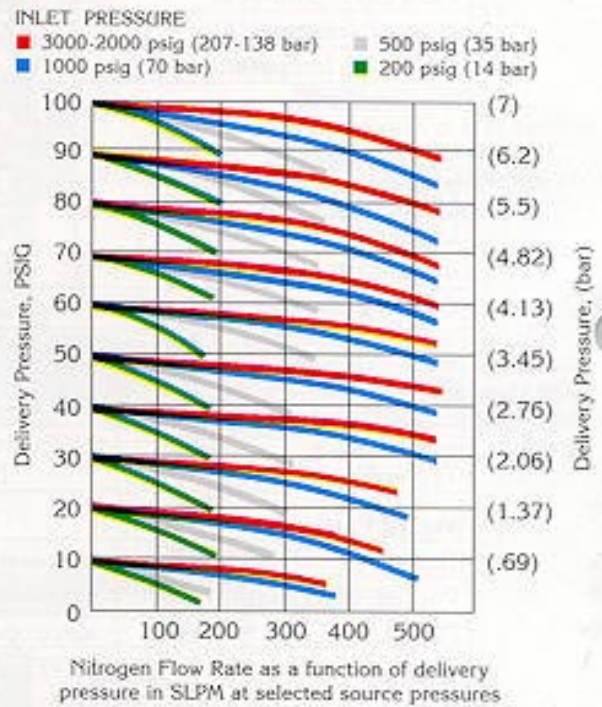
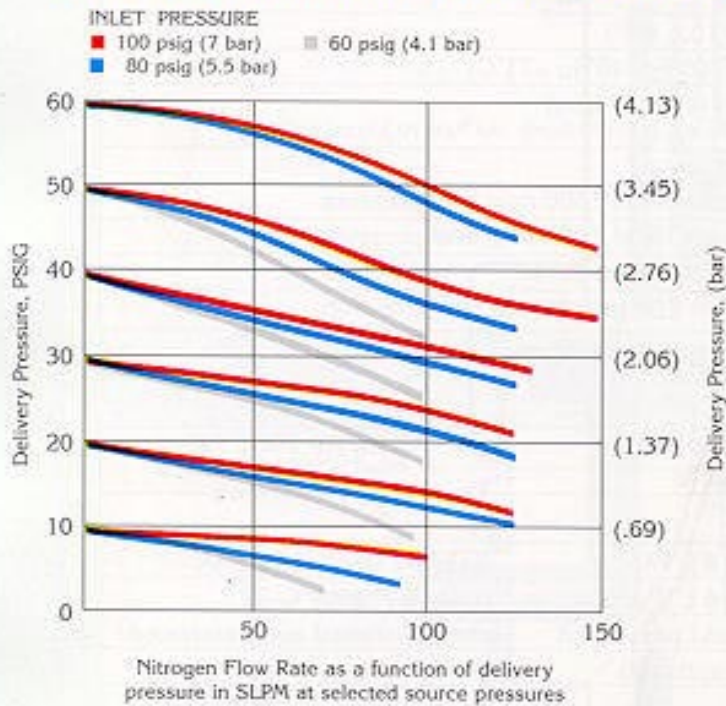

ORDERING INFORMATION

Series AP 1900	S Material	M Surface Finish Options	4PW Ports	FV4 - FV4 Connectors Inlet Outlet	40 - V3 Gauges Source Delivery*	p Options
AP1901 = 1-10 psi (.07 to .7 bar) AP1902 = 1-30 psi (.07 to 2 bar) AP1906 = 2-60 psi (.14 to 4 bar) AP1910 = 2-100 psi (.14 to 7 bar)	S = Stainless steel SH = Stainless steel with Hastelloy internals				0 = No gauge V3 = 30-0-30-psi/bar L = 30-0-60 psi/bar	P = Panel installation ring** VS = Vespel seat CGA = Inlet fitting 320, 330, 350 580, 660, 678
	M = 10 μ in. Ra V = 7 μ in. Ra X = 5 μ in. Ra				1 = 30-0-100 psi/bar 10 = 0-1000 psi/bar 40 = 0-4000 psi/bar	
3P = 3 ports (1/4 NPTF) 4P = 4 ports (1/4 NPTF) 2PW = 2 ports butt weld 3PW = 3 ports butt weld 4PW = 4 ports butt weld				FV4 = 1/4 inch face-seal female MV4 = 1/4 inch face-seal male TW4 = 1/4 inch tube stub weld FV6 = 3/8 inch face-seal female MV6 = 3/8 inch face-seal male TW6 = 3/8 inch tube stub weld		FV8 = 1/2 inch face-seal female MV8 = 1/2 inch face-seal male TW8 = 1/2 inch tube stub weld 4 = 1/4 inch NPT female 6 = 3/8 inch NPT female

* Gauge ports are always 1/4 inch face-seal male. ** Panel hole 1.43"