

527 Series Switchover

CRN OH 5216.5C

Automatic Switchover System 316L Stainless Steel Components

The 527 Series Switchover is an automatic switchover system designed to supply a continuous supply of high purity or corrosive gas. The system comes with either flexible pigtails for use with two cylinders or manifold connectors for use with the Maniflex Modular Manifold System. Due to pressure differential considerations, an integral line regulator is available to maintain constant downstream pressure.

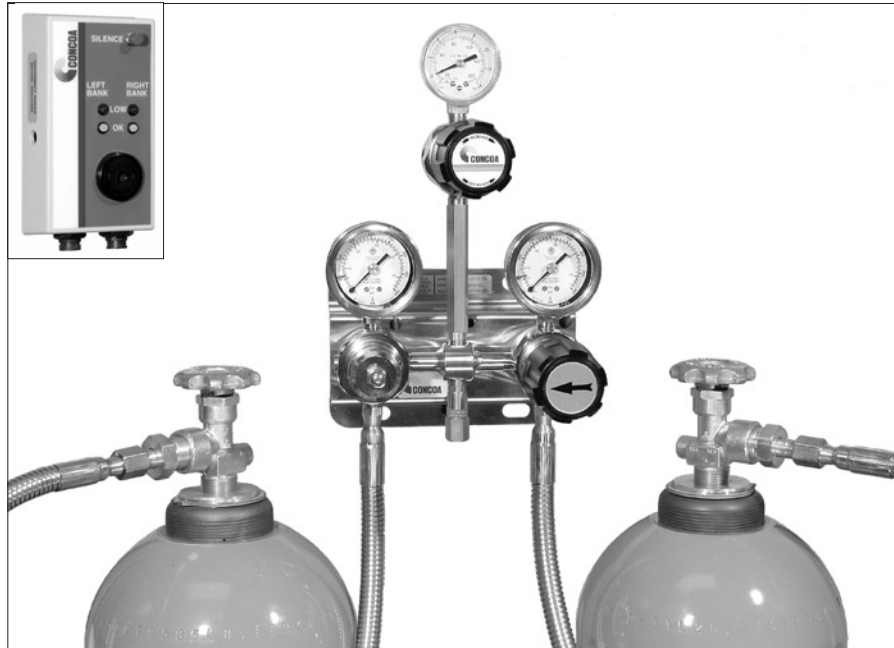

527-5143 shown

Features

- 400 Series stainless steel regulators Capsule® seat
- Metal-to-metal diaphragm seal
No possibility of gas contamination
- User-Friendly Priority Valve
One knob switches cylinder priority
- Check valves in inlet gland
Prevents contamination and back flow.
- Compatible with Maniflex Manifolds
Multiple cylinders per side
- Optional Line Regulator
Stable line pressure during change over
- Optional Pressure Switches and Remote Alarm

Materials

- Bodies*
316L stainless steel barstock
- Diaphragms*
316L stainless steel
- Seats*
PTFE
PCTFE with 4500 PSIG inlet
- Filters*
10 micron sintered stainless steel
- Internal Seals*
PTFE

Specifications

- Maximum Inlet Pressure*
3000 PSIG (210 BAR)
4500 PSIG (310 BAR) optional
- Temperature Range*
-40°F to 140°F (-40°C to 60°C)
- Gauges*
2" diameter stainless steel
- Outlet Connection*
¼" MPT (without line regulator)
¼" FPT (with line regulator)
- Helium Leak Integrity*
1 x 10⁻⁸ scc/sec
- Cv*
0.1
- Weight*
8.25 lbs. (3.71 kg)

Controls Corporation of America, Inc.

1501 Harpers Road • Virginia Beach, Virginia 23454 USA • 1.800.225.0473 • Fax: 757.422.3125 • www.concoa.com

Flow Performance Curves

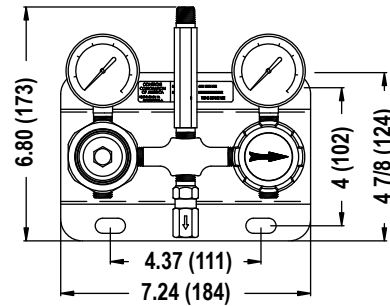
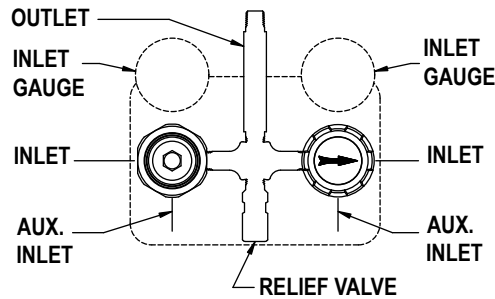
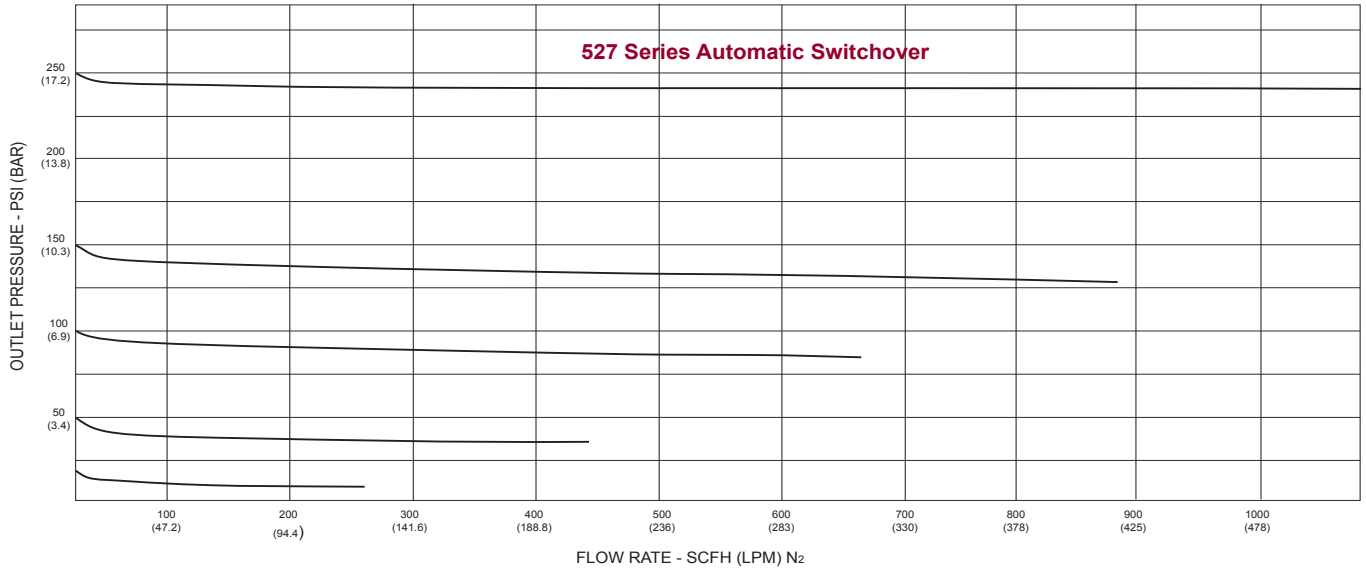

Ordering Information *(For information about how to use this table please see page 4.)*

527	A	B	C	D	-CON
Series 527	Switching Pressure (Priority Right/Left) 1: 125 PSIG/105 PSIG* 2: 70 PSIG/50 PSIG* 3: 100 PSIG/75 PSIG 4: 200 PSIG/170 PSIG 5: 500 PSIG/470 PSIG 7: 150 PSIG/130 PSIG 8: 300 PSIG/270 PSIG <i>*Not available with 4500 PSIG inlet</i> NOTE: Switching pressure must be higher than line regulator pressure selected in column C.	Inlet Connections 0: 1/4" FPT Ports 1: Flexible Stainless Steel Pigtails (36") 2: Manifold Connectors* 3: Flexible Stainless Steel Pigtails (24") 4: Diaphragm Valves with 1/4" FPT Port 5: Diaphragm Valves with Pigtails (36") 6: Diaphragm Valves with Manifold Connectors* 7: Diaphragm Valves with Pigtails (24") 8: Flexible PTFE-lined Pigtails (36") (4500 PSIG maximum inlet pressure) 9: 1/4" FPT Ports (4500 psig maximum inlet pressure) <i>*See page 26 for manifold ordering information</i>	Line Regulator 0: None 1: 0-15 PSIG 2: 0-50 PSIG 3: 0-100 PSIG 4: 0-250 PSIG 5: 0-400 PSIG 7: 0-150 PSIG	Assembly/Gauges 1: 0-4000 PSI/kPa Gauges* No alarm capability 2: 0-4000 BAR/PSI Gauges* No alarm capability 3: 0-4000 BAR/PSI* with Pressure Switches† and 110V Remote Alarm 4: 0-4000 BAR/PSI* with Pressure Switches† and 220V Remote Alarm 5: 0-600 BAR/PSI Gauges No alarm capability 6: 0-600 BAR/PSI with Pressure Switches† and 110V Remote Alarm 7: 0-600 BAR/PSI with Pressure Switches† and 220V Remote Alarm 8: 0-4000 BAR/PSI* with Pressure Switches† and without Remote Alarm 9: 0-600 BAR/PSI with Pressure Switch and Without Remote Alarm <i>*0-6000 PSI gauges with 4500 PSIG maximum inlet option</i> †Intrinsic safety barriers are required for flammable gas service or for use in hazardous environments.	Pigtail Please specify inlet connection (if applicable) CGA DIN 477 BS 341 and others available