



# 400 Series Regulators

# 405 SERIES

The 405 Series regulators are intended for secondary pressure control of non-corrosive, high purity or liquefied gases or as point of use pressure control in high purity gas distribution systems.

- Single Stage
- Brass Barstock Body
- Four Port Configuration
- 316L Stainless Steel Diaphragm



405 2021-000 shown

## Typical Applications

- Bulk gas distribution systems
- Gas and liquid chromatography
- High purity carrier gases
- Zero, span, and calibration gases
- High purity chamber pressurization
- Liquefied hydrocarbon gas control
- Control of cryogenic gases

## Features

- Metal-to-Metal Diaphragm Seal**  
No possibility of gas contamination
- CAPSULE® Seat**  
Increased serviceability and life
- Brass Barstock Body**  
Smooth surface finish
- Front and Rear Panel-Mountable**  
Versatile system configuration
- Pressure Ranges 0-15 to 0-500 PSIG (0-1 to 0-34 BAR)**  
Broad range of applications
- 3000 PSIG (210 BAR) Inlet Pressure Rating**  
Safe use with high pressure cylinders
- Pipe Away Relief Valve**  
Safely vents exhaust gases

## Materials

- Body**  
Brass barstock
- Bonnet**  
Brass barstock
- Seat**  
PTFE
- Filter**  
10 micron sintered bronze
- Diaphragm**  
316L stainless steel
- Internal Seals**  
PTFE

## Specifications

- Maximum Inlet Pressure**  
3000 PSIG (210 BAR)
- Temperature Range**  
-40°F to 140°F (-40°C to 60°C)
- Gauge**  
2" (53mm) diameter brass
- Ports**  
1/4" FPT
- Helium Leak Integrity**  
1 x 10<sup>-9</sup> scc/sec
- Cv**  
0.1 Max outlet 50 PSIG (3.5 BAR) or below  
0.2 Max outlet above 50 PSIG (3.5 BAR)  
*See page 203 for flow curves*
- Weight (405 2021-000)**  
2.71 lbs. (1.23 kg)

# 400 Series Regulators



## Installation Dimensions

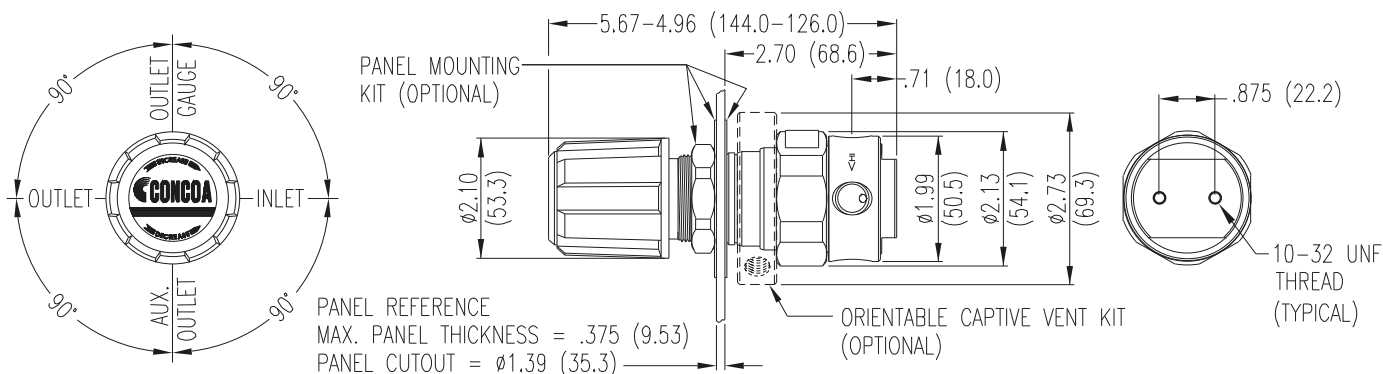

## Ordering Information

405	A	B	C	D	-CON	Options	
Series 405	Outlet Pressure	Outlet Gauge	Inlet Gauge	Outlet Assemblies	Assembly/ Gauges	Inlet Connections	Installed Options
	<b>1:</b> 0-15 PSIG (0-1 BAR)	30"-0-30 PSIG/ -1-0-2 BAR	<b>0:</b> None	<b>0:</b> 1/4" FPT port	<b>0:</b> Bare body	<b>000:</b> 1/4" FPT	<b>D:</b> Deep purge
	<b>2:</b> 0-50 PSIG (0-3.5 BAR)	30"-0-100 PSIG/ -1-0-7 BAR		<b>1:</b> 1/4" MPT	<b>1:</b> Cleanroom assembly (PSIG/kPa gauges)	<b>TF2:</b> 1/8" tube	<b>M:</b> Protocol station
	<b>3:</b> 0-100 PSIG (0-7 BAR)	30"-0-200 PSIG/ -1-0-14 BAR		<b>2:</b> 1/4" tube fitting	<b>2:</b> Cleanroom assembly (BAR/PSIG gauges)	<b>TF4:</b> 1/4" tube	<b>Q:</b> Protocol purge station
	<b>4:</b> 0-250 PSIG (0-17 BAR)	0-400 PSIG/ 0-27 BAR		<b>3:</b> Diaphragm valve 1/4" tube fitting	<b>6:</b> Mirror image (PSIG/kPa gauges)	<b>TF6:</b> 3/8" tube	
	<b>5:</b> 0-500 PSIG (0-34 BAR)**	0-1000 PSIG/ 0-70 BAR		<b>4:</b> Diaphragm valve 1/4" MPT	<b>7:</b> Mirror image (BAR/PSIG gauges)	<b>M06:</b> 6mm tube	
	<b>7:</b> 0-150 PSIG (0-10 BAR)	30"-0-200 PSIG/ -1-0-14 BAR		<b>5:</b> Needle valve 1/4" MPT			
	<i>*Standard assembly does not include relief valve</i>			<b>6:</b> 1/8" tube fitting			
				<b>7:</b> 3/8" tube fitting			
				<b>8:</b> Diaphragm valve 1/8" fitting			
				<b>9:</b> Diaphragm valve 1/4" FPT			
				<b>A:</b> 3/8" BSP RH fitting			
				<b>B:</b> Diaphragm valve 3/8" tube fitting			
				<b>C:</b> 3/8" BSP LH fitting			
				<b>D:</b> 6mm brass hose barb (Not available if A=4 or 5)			
				<b>G:</b> 1/8" stainless steel tube fitting			
				<b>H:</b> 1/4" stainless steel tube fitting			
				<b>M:</b> 6mm tube fitting			
				<b>S:</b> Diaphragm valve 6mm tube fitting			

## Related Options

Order No.	Description
550 0002	Panel mount kit
550 0001	Captured vent kit
476 0002	Helium Leak certification

# Regulator Flow Curves



## Flow Curves for 403, 405, 425, 435, 445 Series

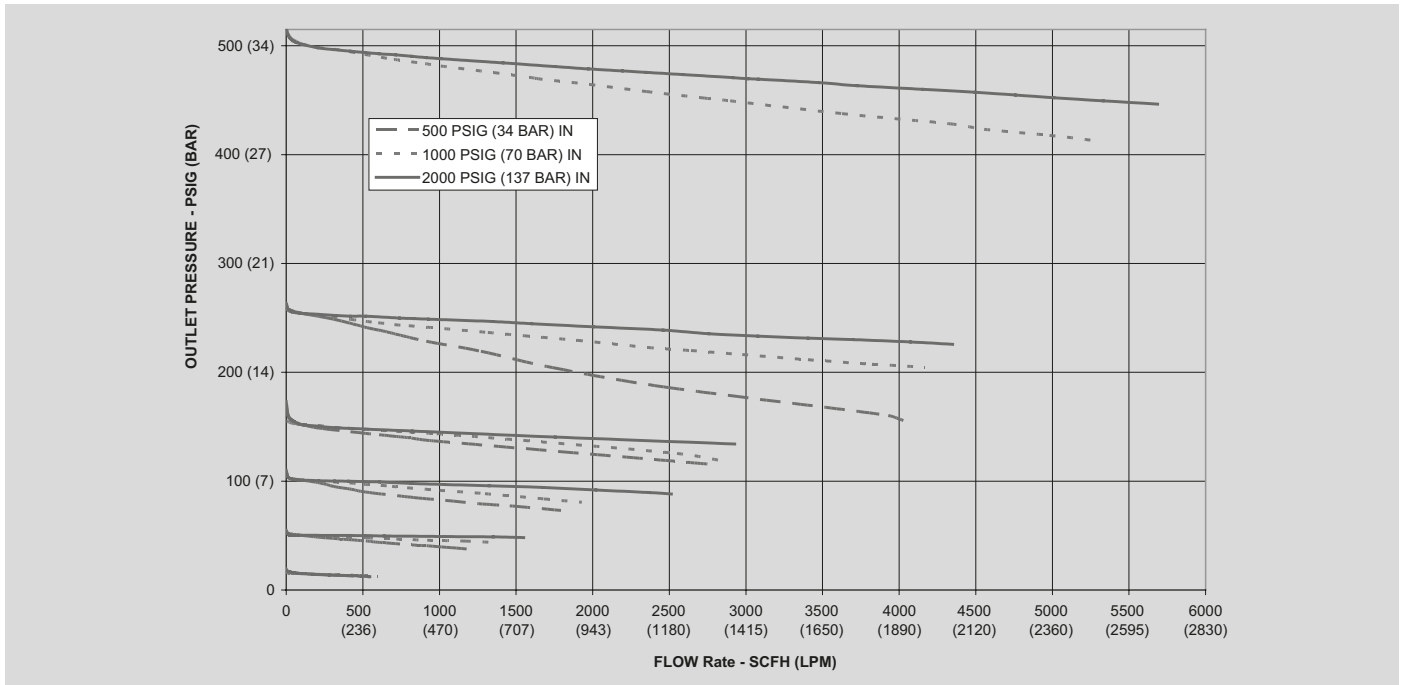

## Flow Curves for 492, 493 Series

