



Lab Master LGT510 Series

5.0 Purity Two Stage Nickel Plated Brass Barstock Diaphragm
Cylinder Regulator – Acetylene



The Lab Master LGT510 Series two stage diaphragm cylinder regulators are designed for primary pressure gas control of high purity Acetylene gas up to grade 5.0 purity (99.999%), on applications where constant delivery pressure is required as cylinder pressure decreases.

- **LGT510 Series** | Two Stage Diaphragm Cylinder Regulator – Acetylene, EPDM Seal, EPDM Pressure Relief Valve



★ FEATURES

- Six port configuration
- Encapsulated seat design
- Low wetted surface area
- Full range of inlet and outlet fittings
- Side entry

📦 MATERIAL

▪ Body	Nickel Plated Brass Barstock
▪ Bonnet	High Strength Alloy
▪ Diaphragm	316L Stainless Steel
▪ Bonnet Seal	PTFE
▪ Pressure Relief Valve Seal	EPDM
▪ Valve Seat	Polyamide (Nylon®)
▪ Filter	10 Micron 316L Stainless Steel

👍 SPECIFICATION

▪ Maximum Inlet Pressure	25 bar (360 PSI)
▪ Delivery Pressure Range	1.0 bar (15 PSI) 1.5 bar (22 PSI)
▪ Gauges	50mm (2") Diameter
▪ Ports	1/4" NPT Female
▪ Temperature Range	-20° C to +60° C (-4° F to +140° F)
▪ Weight	1.7 kg (3.8 lb) **

** Cylinder connection not included

✓ FLOW PERFORMANCE

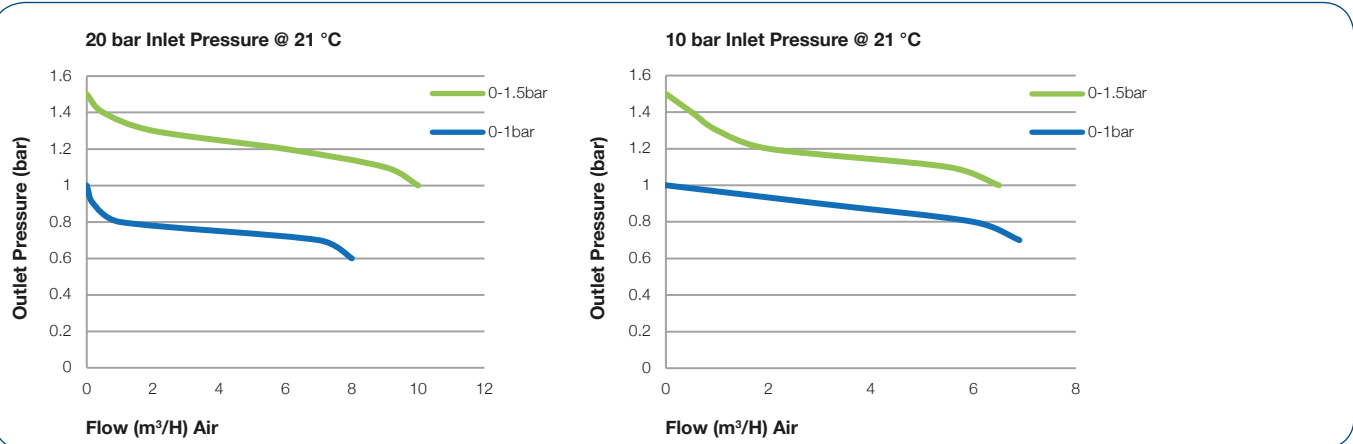

DRAWINGS

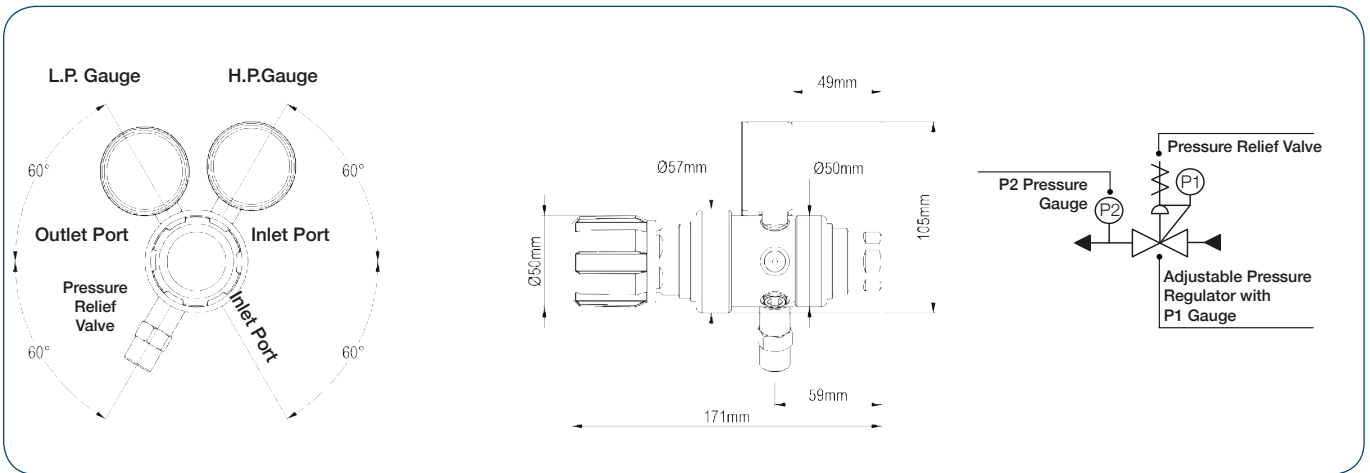

MODEL NO. SELECTOR GUIDE

Example for a Model No. for LGT510 Series

Product Type	Inlet Pressure Bar [PSI]	Outlet Pressure Bar [PSI]	Inlet Pressure Gauge	Outlet Pressure Gauge	Inlet/Cylinder Connection	Outlet Connection	Options
LGT510-	01-	02-	00-	00-	000-	00-	A
LGT510	01 25 [360]	01 0 to 1.0 [15]	00 No Gauge Fitted	00 No Gauge Fitted	000 1/4" NPT Female	00 1/4" NPT Female	A No Options Selected
		02 0 to 1.5 [22]	01 bar/PSI	01 bar/PSI	001 1/8 Stainless Steel Compression	01 1/8 Stainless Steel Compression	B Regulator Tee Purge FKM
			10 Plugged Port	10 Plugged Port	002 1/4 Stainless Steel Compression	02 1/4 Stainless Steel Compression	C Regulator Tee Purge EPDM
					003 6mm Stainless Steel Compression	03 6mm Stainless Steel Compression	K Certificate of Conformity (CoC)
					004 1/4 NPT Male	04 1/4 NPT Male	P Calibration / Pressure Test Certificate
					008 G3/8 BSP L/H Brass Male	08 G3/8 BSP L/H, Brass, Male	X Special Instruction
					011 BS341 No.4 (Base Entry)	10 Isolation Valve, 1/4 NPT Female, EPDM Seal	
					012 BS341 No.4	12 Isolation Valve, 1/8 Stainless Steel Compression, EPDM Seal	
					027 DIN477 No.3	14 Isolation Valve, 1/4 Stainless Steel Compression, EPDM Seal	
					028 DIN477 No. 3.1	16 Isolation Valve, 6mm Stainless Steel Compression, EPDM Seal	
					050 CGA 510	18 Isolation Valve, 1/4 NPT Male, EPDM Seal	
					For our complete range of cylinder connections refer to 'Cylinder Connections Data'	22 Isolation Valve, G3/8 BSP L/H Brass Male, EPDM Seal	